

DISCOVERY

Advanced PIR Motion Detector



Visonic Ltd

Installation Instructions

1. FEATURES

- Integral swivel bracket for wall or ceiling installation
- Sealed chamber protects the optical system
- Programmable pulse counter (1, 2 or 3 pulses)
- Three-position vertical adjustment
- Low current consumption
- Temperature compensation
- Terminal for connecting an E.O.L. resistor
- Snap-in pet alley mask
- White light protection
- Elegantly styled, sturdy case
- Keyhole-shaped slot for easy removal of PCB

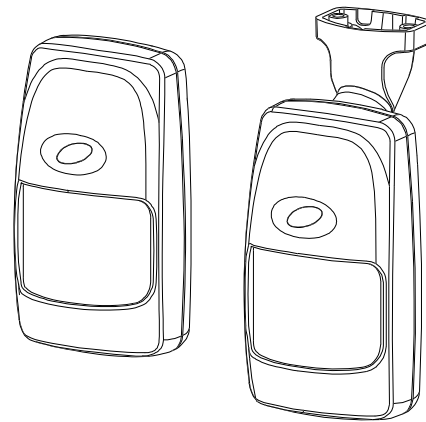

Figure 1. The DISCOVERY Detector

2. SPECIFICATIONS

OPTICAL

Detection Pattern: 90° wide angle lens with 36 beams in 3 detection layers. Max. coverage is 15 x 15 m (50 x 50 ft).

Pet Alley: Plastic mask may be fitted internally, leaving only 18 beams in a single layer, with the same view angle and coverage area as above.

Adjustment: 3-position vertical adjustment scale: PET, FAR and NEAR.

LENS NO. 100A

Max. Coverage: 15 x 15 m / 90°
(50 x 50 ft / 90°)

TOP VIEW

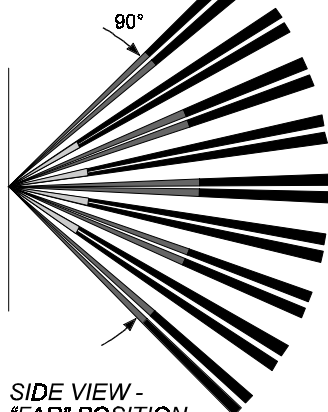

SIDE VIEW - "FAR" POSITION

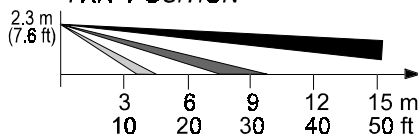

Figure 2. Coverage Pattern

ELECTRICAL

Input Voltage: 9 to 16 VDC

Current @ 12 VDC:

- 10 mA standby,
- 18 mA on alarm (LED ON)

Alarm Relay: Normally closed (fail-safe) contacts with 18-ohm resistor in series. Rating - 0.1 A resistive / 24 VDC.

Tamper Output: Normally closed contacts rated at 50 mA resistive / 12 VDC.

Alarm Period: 2-3 seconds.

Pulse Counter: 3 position selector - 1, 2 or 3 pulse operation.

LED Control: Walk test enabled / disabled by internal link

Detector Type: Dual element low-noise pyroelectric sensor.

MOUNTING

Height: Up to 3.6 m (12 ft)

Room Size:

- Up to 15 m (50 ft) in the "FAR" and "PET" positions
- 2 - 8 m (6 - 24 ft) in the NEAR position.

Installation Options:

- Surface or corner (without bracket);
- surface or ceiling (with bracket).

Bracket Adjustment: 20° downward, 20° left and right.

ENVIRONMENTAL

RFI Protection: >30 V/m up to 1000 MHz.

Operating Temperatures: -10°C to 50°C (14°F to 122°F).

Storage Temperatures: -20°C to 60°C (-4°F to 140°F).

Compliance with Standards: This device complies with the European Council Directive EMC 89/336/EEC & 92/31/EEC, and bears the CE mark and certification.

PHYSICAL

Dimensions (H x W x D): 117 x 65 x 47 mm.

(4-5/8 x 2-9/16 x 1-7/8 in.).

Weight: 98 g (3.4 oz) without bracket, 113 g (4 oz) with bracket.

3. INSTALLATION

3.1 Installation Hints

To minimize false alarms:

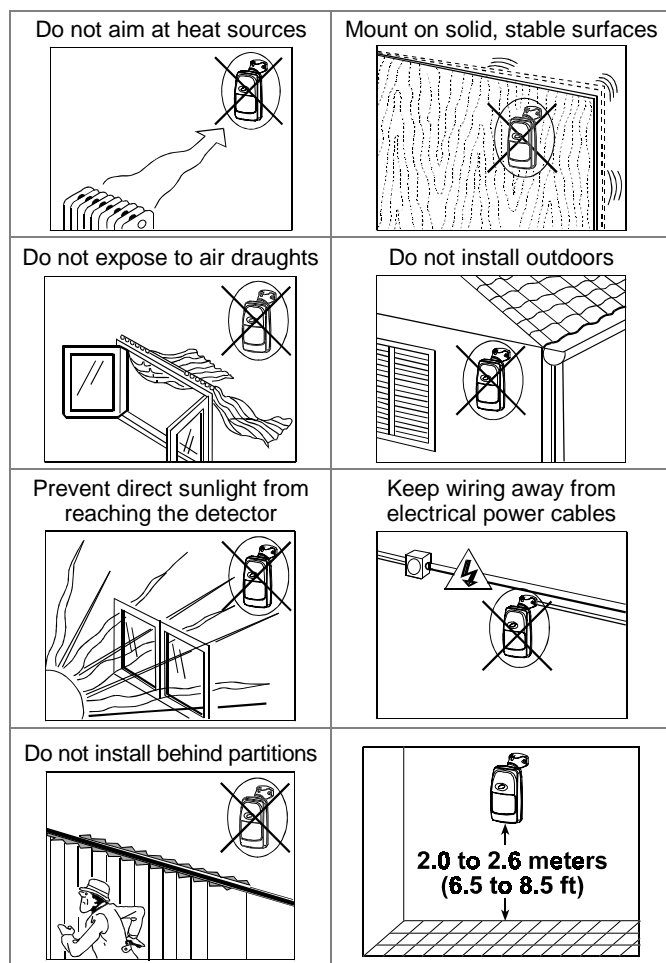

3.2 Mounting without Swivel Bracket

A. Remove the front cover as shown in Figure 3.

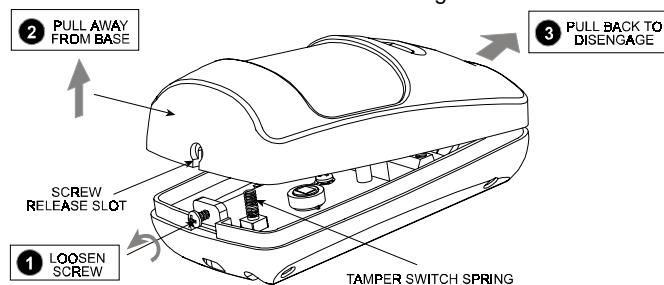

Figure 3. Cover Removal

B. Loosen the vertical adjustment screw, slide the PCB down and remove it via the "keyhole" (see Figure 4).

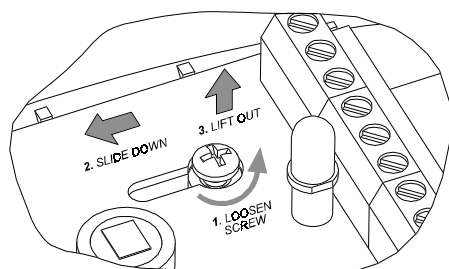

Figure 4. PCB Removal

C. Pull the PCB straight out and put it aside until required again.

D. Refer to Figure 5 and punch out the mounting knockouts at the rear wall of the base (for surface mounting) or mounting knockouts at the angled sides of the base (for corner mounting).

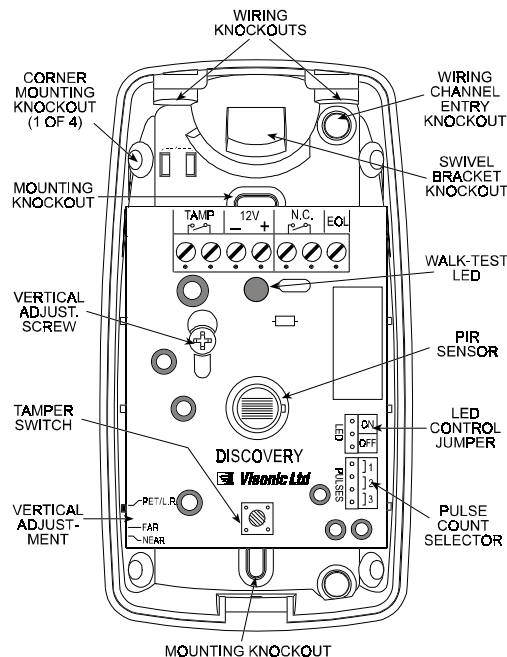

Figure 5. Inside View

- E. Punch out any one of the wiring knockouts shown in Figure 5.
- F. Hold the base against the wall at the selected installation location and mark the points for drilling.
- G. Drill the holes and insert the plastic dowels supplied (if necessary).
- H. Pass the wires through the wiring inlets into the base and attach the base to the wall using the screws supplied.
- I. Return the PCB to its place: align the "keyhole" with the head of the vertical adjustment screw, press the PCB against the base, slide the PCB up and temporarily tighten the screw.
- J. Proceed to wire the terminal block as instructed in Para. 3.5.

3.3 Mounting with Swivel Bracket

- A. Remove the front cover as shown in Figure 3.
- B. Remove the PCB (see Figure 4) and put it temporarily aside.
- C. Punch out the large knockout in the round bulge at the top part of the base (see Figure 6)

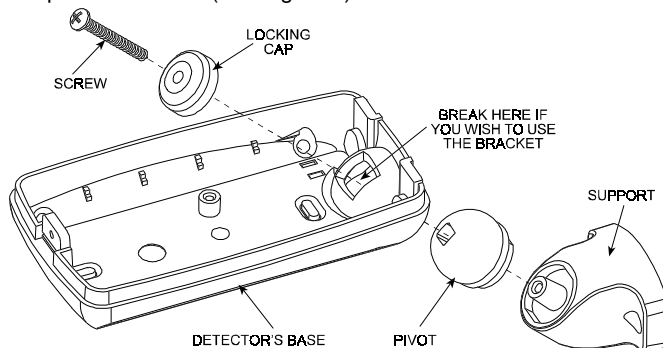

Figure 6. Attaching the Bracket

- D. Assemble the bracket as shown in Figure 6.
- E. Rotate the bracket to the desired position (see Figure 7) but do not yet tighten the screw fully.

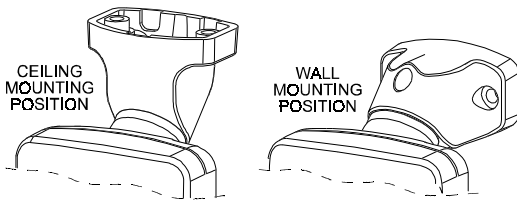

Figure 7. Wall and Ceiling Positions of Bracket

F. Punch out the selected wiring knockouts in the bracket (see Figure 8).

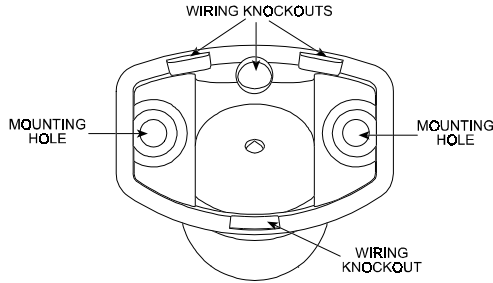

Figure 8. Bracket Base as Viewed from the Rear

- G. Press the bracket against the mounting surface and mark the points for drilling. Drill out the holes and insert plastic dowels.
- H. Route the cable through the bracket and into the detector as shown in Figure 9.
- I. Attach the bracket to the mounting surface using the two screws supplied.

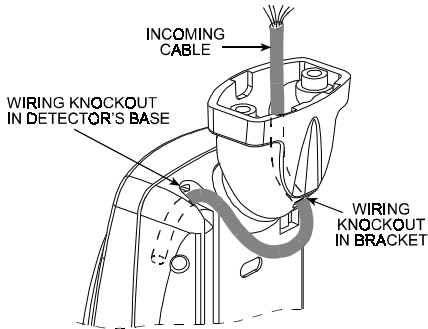

Figure 9. Routing the Cable

J. Tilt down or swivel the detector to face the desired direction. Figure 10 shows the tilt/swivel possibilities.

Notes:

- 1. Once the detector is tilted as required, tighten the bracket assembly screw strongly, to prevent any further change of position.
- 2. With the detector tilted down, the side view patterns shown in Figure 15 do not apply. The actual coverage must be tested very carefully.

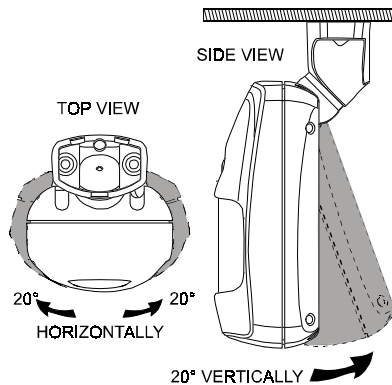

Figure 10. Tilt/Swivel Limits

3.4 Using the Pet Alley Mask

If the presence of pets is expected within the protected site, proceed as follows:

- A. Separate the lens retainer from the front cover, as shown in Figure 11.
- B. Push the prefabricated plastic mask into place within the lens retainer, as shown in Figure 12.
- C. Remount the lens retainer within the front cover.

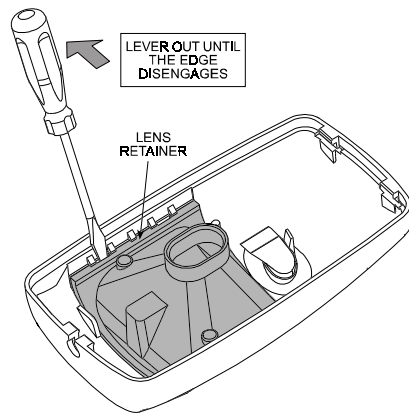

Figure 11. Releasing the Lens Retainer

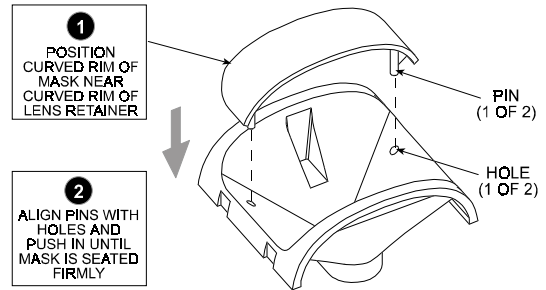

Figure 12. Inserting the Mask into Place

3.5 Wiring

The terminal block wiring shown in Figure 13 is self explanatory.

Note: The E.O.L. terminal is simply a connection point for an E.O.L. resistor, if the circuit requires one.

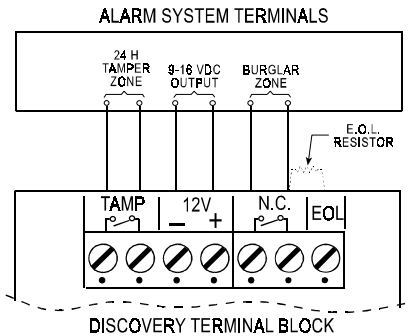

Figure 13. Terminal Block Wiring

3.6 Setting the Pulse Counter

The location of the pulse count selector is indicated in Figure 5. Refer to Figure 14 below and mount the jumper as desired.

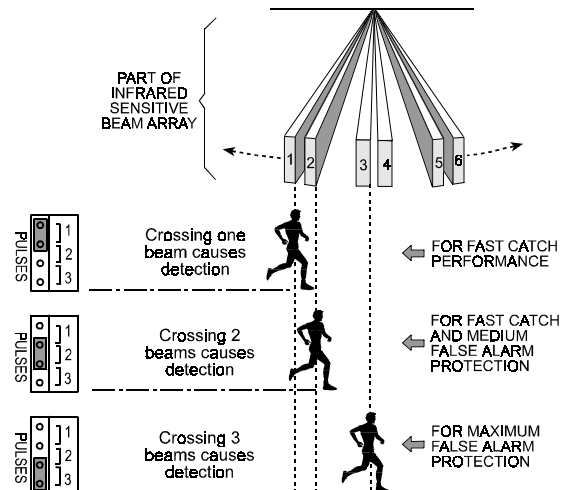

Figure 14. Pulse Counter Setting Options

3.7 Vertical Adjustment

Refer to Figure 15. Slacken the vertical adjustment screw and slide the printed circuit board up or down to obtain the desired coverage. When done, tighten the screw well.

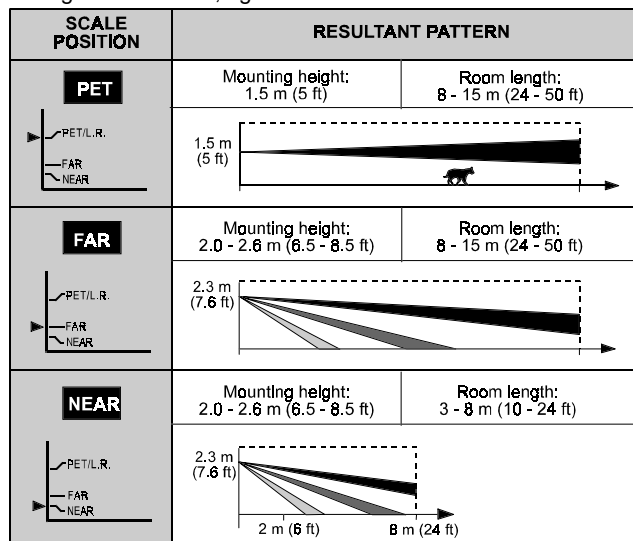

Figure 15. Vertical Adjustment

3.8 Setting the LED Control Jumper

	ON Position Setting the jumper as shown will enable the LED, allowing you to walk test the detector.
	OFF Position: Setting the jumper as shown will disable the walk-test LED.

4. WALK TESTING

- Set the pulse counter jumper, the vertical angle adjustment and the LED control jumper as instructed in Paragraphs 3.6, 3.7 and 3.8, respectively.
- Remount the cover back in its place and fasten the case closure screw.
- Walk across the detector's field of view at various distances from the detector, and verify proper detection throughout the detector's coverage area (the red LED will illuminate for several seconds each time your motion is detected).

Note: If the LED is disabled, you may use the control panel's visual and audible indicators to verify proper function of the detector.

Attention! To assure proper function of the detector, the range and coverage area should be checked at least twice a year. Furthermore, the user should be instructed to perform a walk test at the far end of the coverage pattern to assure an alarm signal prior to each time the alarm system is armed.

WARRANTY

Visonic Ltd. and/or its subsidiaries and its affiliates ("the Manufacturer") warrants its products hereinafter referred to as "the Product" or "Products" to be in conformance with its own plans and specifications and to be free of defects in materials and workmanship under normal use and service for a period of twelve months from the date of shipment by the Manufacturer. The Manufacturer's obligations shall be limited within the warranty period, at its option, to repair or replace the product or any part thereof. The Manufacturer shall not be responsible for dismantling and/or reinstallation charges. To exercise the warranty the product must be returned to the Manufacturer freight prepaid and insured.

This warranty does not apply in the following cases: improper installation, misuse, failure to follow installation and operating instructions, alteration, abuse, accident or tampering, and repair by anyone other than the Manufacturer.

This warranty is exclusive and expressly in lieu of all other warranties, obligations or liabilities, whether written, oral, express or implied, including any warranty of merchantability or fitness for a particular purpose, or otherwise. In no case shall the Manufacturer be liable to anyone for any consequential or incidental damages for breach of this warranty or any other warranties whatsoever, as aforesaid.

This warranty shall not be modified, varied or extended, and the Manufacturer does not authorize any person to act on its behalf in the modification, variation or extension of this warranty. This warranty shall apply to the Product only. All products, accessories or attachments of others used in conjunction with the Product, including batteries, shall be covered solely by their own warranty, if any. The Manufacturer shall not be liable for any damage or loss whatsoever, whether directly, indirectly, incidentally, consequentially or otherwise, caused by the malfunction of the Product due to products, accessories, or attachments of others, including batteries, used in conjunction with the Products.

The Manufacturer does not represent that its Product may not be compromised and/or circumvented, or that the Product will prevent any death, personal and/or bodily injury and/or damage to property resulting from burglary, robbery, fire or otherwise, or that the Product will in all cases provide adequate warning or protection. User understands that a properly installed and maintained alarm may only reduce the risk of events such as burglary, robbery, and fire without warning, but it is not insurance or a guarantee that such will not occur or that there will be no death, personal damage and/or damage to property as a result.

The Manufacturer shall have no liability for any death, personal and/or bodily injury and/or damage to property or other loss whether direct, indirect, incidental, consequential or otherwise, based on a claim that the Product failed to function. However, if the Manufacturer is held liable, whether directly or indirectly, for any loss or damage arising under this limited warranty or otherwise, regardless of cause or origin, the Manufacturer's maximum liability shall not in any case exceed the purchase price of the Product, which shall be fixed as liquidated damages and not as a penalty, and shall be the complete and exclusive remedy against the Manufacturer.

Warning: The user should follow the installation and operation instructions and among other things test the Product and the whole system at least once a week. For various reasons, including, but not limited to, changes in environmental conditions, electric or electronic disruptions and tampering, the Product may not perform as expected. The user is advised to take all necessary precautions for his /her safety and the protection of his/her property.

6/91



VISONIC LTD. (ISRAEL): P.O.B 22020 TEL-AVIV 61220 ISRAEL. PHONE: (972-3) 645-6789, FAX: (972-3) 645-6788
 VISONIC INC. (U.S.A.): 10 NORTHWOOD DRIVE, BLOOMFIELD CT. 06002-1911. PHONE: (860) 243-0833, (800) 223-0020 FAX: (860) 242-8094
 VISONIC LTD. (UK): UNIT 1, STRATTON PARK, DUNTON LANE, BIGGLESWADE, BEDS. SG18 8QS. PHONE: (01767) 600857 FAX: (01767) 601098
 ©VISONIC LTD. 1998 DISCOVERY D-1250-0 NEW: DE1250- (REV. 2, 4/98)

